

## TECHNICAL DATASHEET

### Incremental Encoder F 10

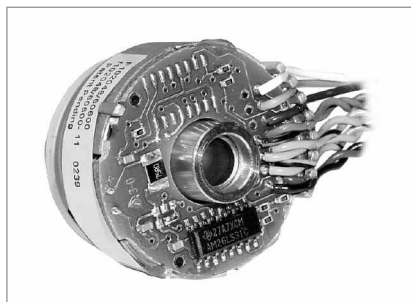

- Compact hollowshaft motor encoder, ideal for BLDC, DC-Servo and Stepper feedback
- Through hollow shaft Ø 6 mm
- Incremental signals A, B, N
- Resolution up to 2048 ppr
- 6 or 10 pole commutation signals
- Frequency response to 300 kHz
- Resolver compatible mounting
- Operating temperature up to 120 °C
- Mounting depth: 22.4 mm



#### NUMBER OF PULSES

1024, 2048;  
optional 6 or 10 pole commutation signals

#### GENERAL INFORMATION

The type F10 encoder provides high performance, cost effective feedback for stepper and servo motor applications. The F10 offers compact package dimensions and flying leads for a low-profile installation. A size 10 servo ring allows easy mounting and replacement of pancake resolvers with high tolerance to motor shaft movement and 360 degrees of adjustment to align the signal outputs to the shaft position.

#### TECHNICAL DATA mechanical

Housing diameter	31.7 mm
Mounting depth	22.5 mm
Shaft diameter	6 mm (Hub shaft)
Flange (Mounting of housing)	Servo flange
Hollow shaft tolerance	+0.025 mm/ -0.000 mm (+0.001"/ -0.000")
Mounting	26.54 mm (1.045") flexible servo ring (size 10 pancake resolver equivalent)
Axial endplay of mounting shaft (hubshaft)	± 0.25 mm
Radial runout of mating shaft (hubshaft)	Includes shaft perpendicularity to mounting surface: 0.05 mm
Max. speed	max. 5000 rpm (continuous), max. 12 000 rpm (short term)
Acceleration	100 000 rad/s <sup>2</sup>
Bearing life	[(3.6 x 10 <sup>9</sup> ) / rpm] hours, e.g. 605 000 hours at 6000 rpm
Moment of inertia	approx. 1.6 gcm <sup>2</sup>
Vibration resistance (DIN EN 60068-2-6)	2.5 g at 5 to 2000 Hz
Shock resistance (DIN EN 60068-2-27)	50 g for 6 ms duration
Operating temperature	0 °C ... +120 °C
Storage temperature	0 °C ... +120 °C
Relative humidity	90 %, non-condensing
Material shaft	Brass
Material housing	Cast aluminum
Material flange	Aluminum
Material disk	0.76 mm thick glass
Weight	approx. 45 g
Connection	Flying leads

## TECHNICAL DATASHEET

### Incremental Encoder F 10

#### TECHNICAL DATA electrical

Supply voltage	DC 5 V $\pm$ 10 %
Max. current w/o load	100 mA (Incremental and Commutation, w/o load)
Code	Incremental with commutation, optical
Accuracy	Incremental signals: $\pm$ 2.5 arc-mins. max. (edge to edge) Commutation signals: $\pm$ 6 arc-mins. max.
Max. pulse frequency	300 kHz
Phasing	Incremental signals (A leads B): A leads B by 90° for ccw shaft rotation viewing the shaft clamp end of the encoder Commutation signals (U leads V leads W): U leads V leads W by 120°
Index to u channel	$\pm$ 1° mech. index pulse center to U channel edge
Index pulse width (N)	90° gated A and B low
Standard output versions	NPN-O.C. (S): A, B, N RS422: A, B, N, $\bar{A}$ , $\bar{B}$ , $\bar{N}$ NPN-O.C. (commutation): U, V, W RS422 (commutation): U, V, W, $\bar{U}$ , $\bar{V}$ , $\bar{W}$
Number of pulses	1024, 2048
Output current	Incremental: $\pm$ 40 mA (RS422) Commutation: 8 mA (NPN-O.C) or $\pm$ 40 mA (RS 422)

#### ELECTRICAL CONNECTIONS

Function <sup>1</sup>	Colour
VCC	red
GND	black
$\bar{A}$	blue/black
A	blue
$\bar{B}$	green/black
B	green
$\bar{N}$	violet/black
N	violet
$\bar{U}$	brown/black
U	brown
$\bar{V}$	grey/black
V	grey
$\bar{W}$	white/black
W	white

<sup>1</sup> availability of function depends on version

## TECHNICAL DATASHEET

### Incremental Encoder F 10

#### DIMENSIONED DRAWINGS

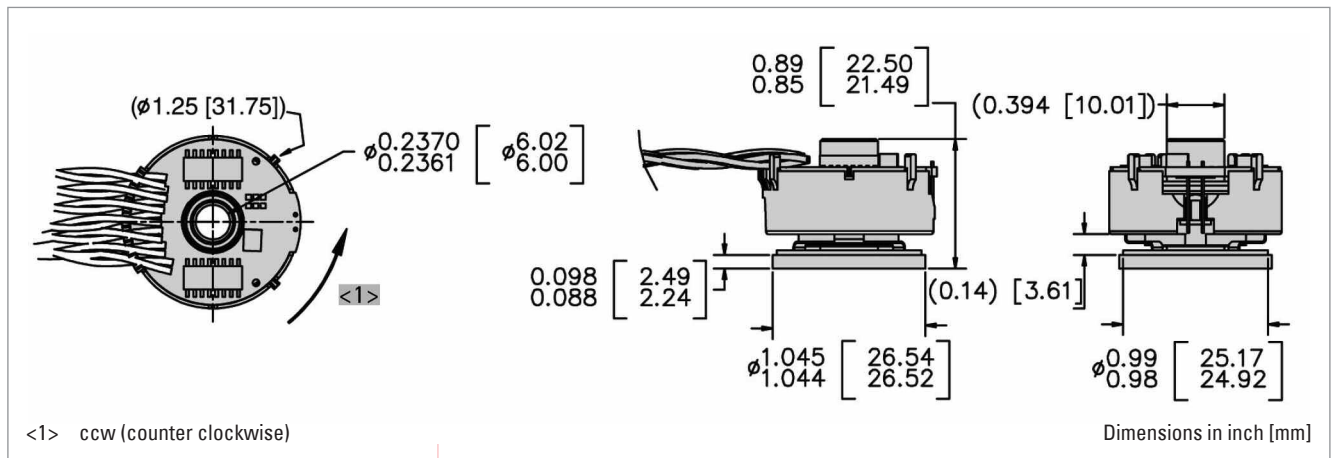

#### OUTPUT WAVEFORMS

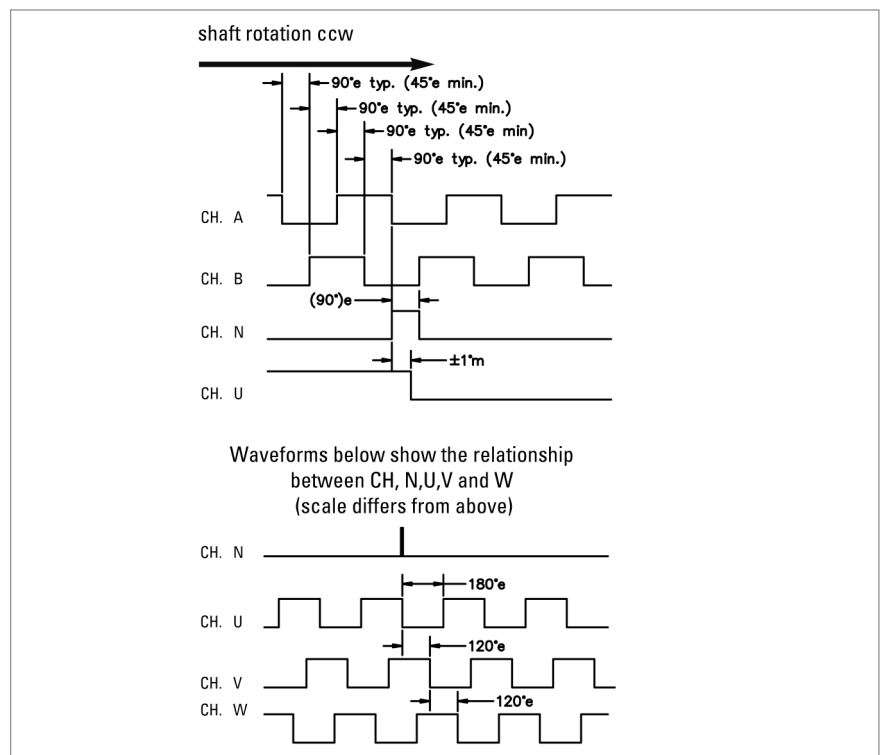

## TECHNICAL DATASHEET

### Incremental Encoder F 10

#### ORDERING INFORMATION

Type	Number of pulses <sup>1</sup>	Poles commutation <sup>2</sup>	Electrical <sup>3,4,5</sup>	Shaft / bore	Connection	Mounting
<input type="checkbox"/>	<input type="checkbox"/>	<input type="checkbox"/>	<input type="checkbox"/>	<input type="checkbox"/>	<input type="checkbox"/>	<input type="checkbox"/>
<b>F10</b>	<b>1024</b> <b>2048</b>	<b>0</b> Without <b>6</b> 6 pole <b>C</b> 10 pole	<b>3</b> U inc = DC 5 V, output inc = RS422 <b>6</b> U inc = DC 5 V, output inc = RS422, U com = DC 5 V, output com = NPN-O.C. <b>9</b> U inc = DC 5 V, output inc = RS422, U com = DC 5 V, output com = RS422	<b>4</b> 6 mm/ through bore	<b>0</b> 16.5 cm flying leads	<b>0</b> Servo ring size 10

<sup>1</sup> allowed combinations see available combinations (pulses/poles)

<sup>2</sup> allowed combinations see available combinations (pulses/poles)

<sup>3</sup> U inc: Supply voltage incremental, U com: Supply voltage commutation (only if commutation selected)

<sup>4</sup> Code Electrical "3": only incremental, without commutation

<sup>5</sup> Code Electrical "6", "9": inkremental plus commutation signals

#### Available combinations (pulses/poles)

Pulses ppr	Number of poles		
	0	6	10 (=C)
1024	X	X	X
2048	X	X	X